

Chapter Two

D.C. Circuits

1) Electric Circuits

Different electric circuits (according to their properties) are defined below :

1. Circuit. A circuit is a closed conducting path through which an electric current flows.

2. Parameters. The various elements of an electric circuit are called its parameters like resistance, inductance and capacitance.

3. Electric Network. A combination of various electric elements, connected in any manner, is called an electric network.

4. Passive Network is one which contains no source of e.m.f. in it.

5. Active Network is one which contains one or more than one source of e.m.f.

6. Node is a junction in a circuit where two or more circuit elements are connected together.

7. Branch is that part of a network which lies between two junctions.

8. Loop. It is a close path in a circuit in which no element or node is encountered more than once.

9. Mesh. It is a loop that contains no other loop within it. For example, the circuit of Fig. 1.1(a) has six branches, five nodes, three loops and two meshes whereas the circuit of Fig. 1.1(b) has four branches, two nodes, six loops and three meshes.

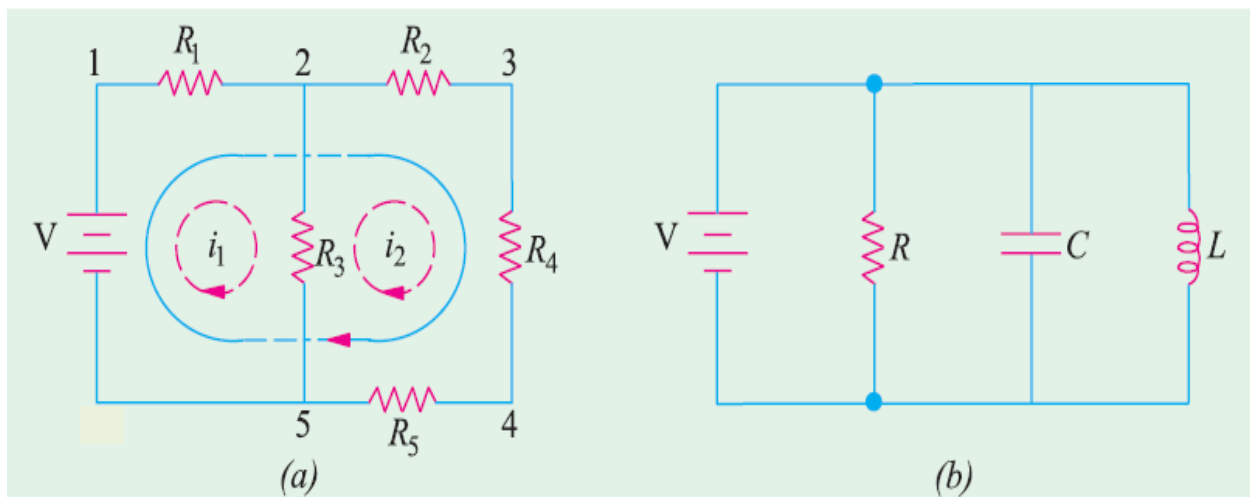

Fig. 1.1

2)Electrical Current

- *Electrical current consists of a flow of electric charges.
- *The SI (standard international) unit for measuring the rate of flow of electric charge is the ampere (A).
- *Electric current is measured using an ammeter.
- *A solid conductive metal contains free electrons (conduction electrons).

$$I = \frac{Q}{t}$$

I = amperes (A)
 Q = coulombs (C)
 t = seconds (s)

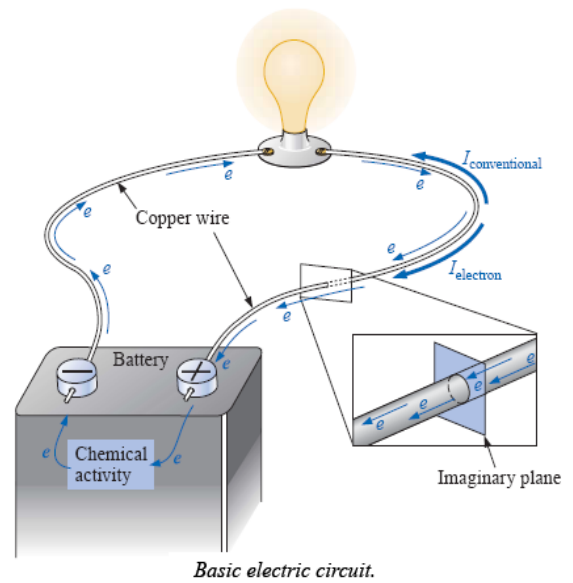

3)Effect of Electric Current

It is a matter of common experience that a conductor, when carrying current, becomes hot after some time. An electric current is just a directed flow or drift of electrons through a substance. The moving electrons as they pass through molecules of atoms of that substance, collide with other electrons. This electronic collision results in the production of heat. This explains why passage of current is always accompanied by generation of heat.

4)Resistance

It may be defined as the property of a substance due to which it opposes (or restricts) the flow of electricity (i.e., electrons) through it. The practical unit of resistance is ohm Ω .

Table 1.1. Multiples and Sub-multiples of Ohm

<i>Prefix</i>	<i>Its meaning</i>	<i>Abbreviation</i>	<i>Equal to</i>
Mega-	One million	M Ω	$10^6 \Omega$
Kilo-	One thousand	k Ω	$10^3 \Omega$
Centi-	One hundredth	-	-
Milli-	One thousandth	m Ω	$10^{-3} \Omega$
Micro-	One millionth	$\mu \Omega$	$10^{-6} \Omega$

5) Law of Resistance

The resistance R offered by a conductor depends on the following factors :

- (i) It varies directly as its length, l .
- (ii) It varies inversely as the cross-section A of the conductor.
- (iii) It depends on the nature of the material.
- (iv) It also depends on the temperature of the conductor.

$$R \propto \frac{l}{A} \quad \text{or} \quad R = \rho \frac{l}{A}$$

6) Ohm's Law

This law applies to electric conduction through the conductors and stated as follows :

The ratio of potential difference (V) between any two points on a conductor to the current (I) flowing between them, is constant called R.

In other words, $\frac{V}{I} = \text{constant} \quad \text{or} \quad \frac{V}{I} = R$

where R is the resistance of the conductor between the two points considered.

But in another way, it simply means that provided R is kept constant, current is directly proportional to the potential difference across the ends of a conductor.

7) Types of D.C. Circuits

D.C. circuits can be classified as:

- 1) *Series circuits (Resistances in Series).*
- 2) *Parallel circuits (Resistances in Parallel).*
- 3) *Series- Parallel circuits (Resistances in Series-Parallel).*

1) Series circuits (Resistances in Series)

When some conductors having resistances R1, R2 and R3 etc. are joined end-on-end as in Fig.1.2, they are said to be connected in series. It can be proved that the equivalent resistance or total resistance between points A and D is equal to the sum of the three individual resistances.

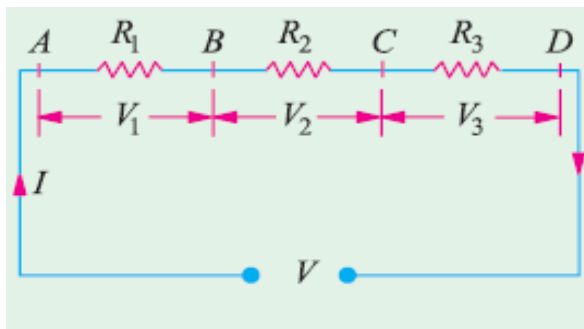

Fig. 1.2

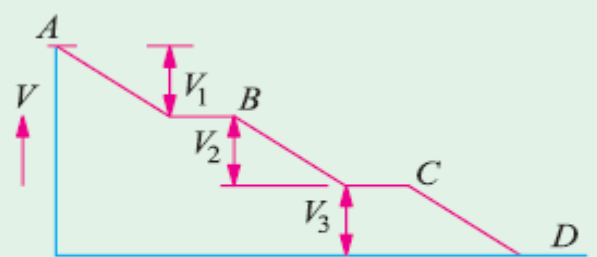

Fig. 1.3

There is a progressive fall in potential as we go from point A to D as shown in Fig. 1.3.

∴ $V = V_1 + V_2 + V_3 = IR_1 + IR_2 + IR_3$ —Ohm's Law
But $V = IR$

where R is the equivalent resistance of the series combination.

∴ $IR = IR_1 + IR_2 + IR_3$ or $R = R_1 + R_2 + R_3$
Also $\frac{1}{G} = \frac{1}{G_1} + \frac{1}{G_2} + \frac{1}{G_3}$ G (Conductance) is the reciprocal of resistance R and its unit is Siemens (S)

As seen from above, the main characteristics of a series circuit are :

1. same current flows through all parts of the circuit.
2. different resistors have their individual voltage drops.
3. voltage drops are additive.
4. applied voltage equals the sum of different voltage drops.
5. resistances are additive.
6. powers are additive.

Voltage Divider Rule

Since in a series circuit, same current flows through each of the given resistors, voltage drop varies directly with its resistance. In Fig. 1.4 is shown a 24-V battery connected across a series combination of three resistors.

Total resistance $R = R_1 + R_2 + R_3 = 12 \Omega$

According to Voltage Divider Rule, various voltage drops are :

$$V_1 = V \cdot \frac{R_1}{R} = 24 \times \frac{2}{12} = 4 \text{ V}$$

$$V_2 = V \cdot \frac{R_2}{R} = 24 \times \frac{4}{12} = 8 \text{ V}$$

$$V_3 = V \cdot \frac{R_3}{R} = 24 \times \frac{6}{12} = 12 \text{ V}$$

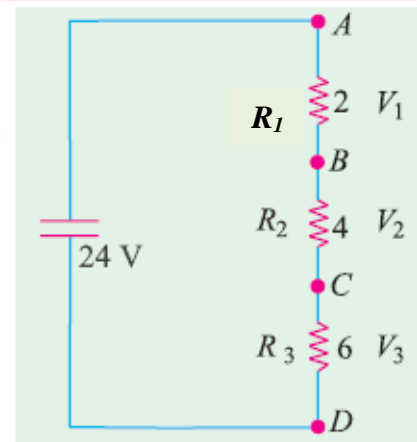

Fig.1.4

2) Parallel circuits (Resistances in Parallel)

$$I = I_1 + I_2 + I_3 = \frac{V}{R_1} + \frac{V}{R_2} + \frac{V}{R_3}$$

Now,

$$I = \frac{V}{R} \text{ where } V \text{ is the applied voltage.}$$

R = equivalent resistance of the parallel combination.

∴

$$\frac{V}{R} = \frac{V}{R_1} + \frac{V}{R_2} + \frac{V}{R_3} \text{ or } \frac{1}{R} = \frac{1}{R_1} + \frac{1}{R_2} + \frac{1}{R_3}$$

Also

$$G = G_1 + G_2 + G_3$$

The main characteristics of a parallel circuit are :

1. same voltage acts across all parts of the circuit
2. different resistors have their individual current.
3. branch currents are additive.
4. conductances are additive.
5. powers are additive.

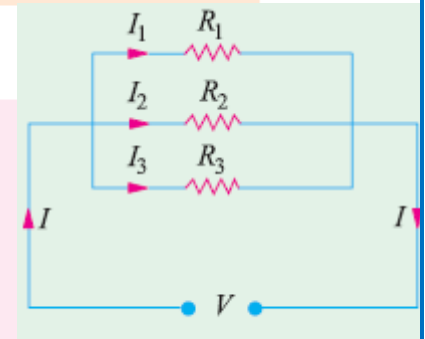

Fig.1.5

Example 1. What is the value of the unknown resistor R in Fig. 1. 6 if the voltage drop across the 500Ω resistor is 2.5 volts ? All resistances are in ohm.

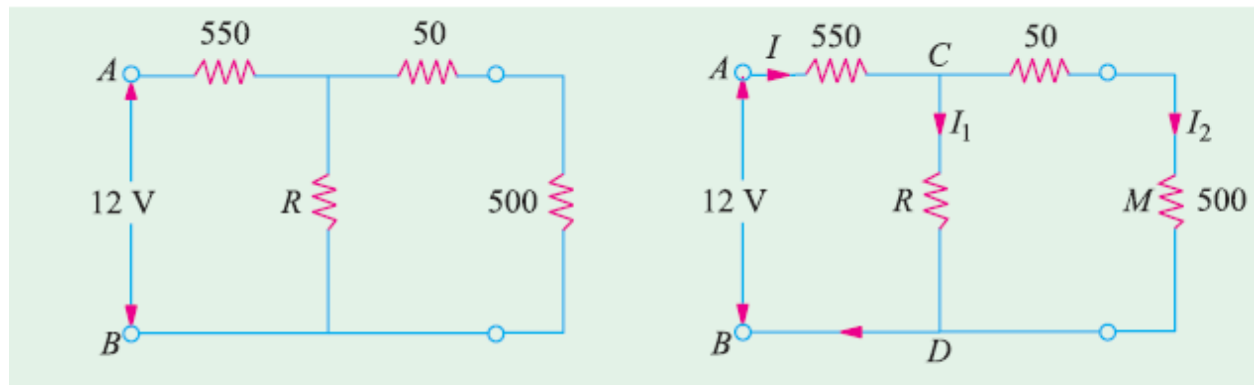

Fig. 1. 6

Solution. By direct proportion, drop on 50Ω resistance = $2.5 \times 50/500 = 0.25 \text{ V}$

$$\text{Drop across CMD or CD} = 2.5 + 0.25 = 2.75 \text{ V}$$

$$\text{Drop across } 550 \Omega \text{ resistance} = 12 - 2.75 = 9.25 \text{ V}$$

$$I = 9.25/550 = 0.0168 \text{ A, } I_2 = 2.5/500 = 0.005 \text{ A}$$

$$I_1 = 0.0168 - 0.005 = 0.0118 \text{ A}$$

$$\therefore 0.0118 = 2.75/R; \quad R = 233 \Omega$$

Delta/Star Transformation

In solving networks (having considerable number of branches) by the application of Kirchoff's Laws, one sometimes experiences great difficulty due to a large number of simultaneous equations that have to be solved. However, such complicated network can be simplified by successively replacing delta meshes by equivalent star system and vice versa.

Suppose we are given three resistances R_{12} , R_{23} and R_{31} connected in delta fashion between terminals 1, 2 and 3 as in Fig. (a). So far as the respective terminals are concerned, these three given resistances can be replaced by the three resistances R_1 , R_2 and R_3 connected in star as shown in Fig. (b). These two arrangements will be electrically equivalent if the resistance as measured between any pair of terminals is the same in both the arrangements. Let us find this condition.

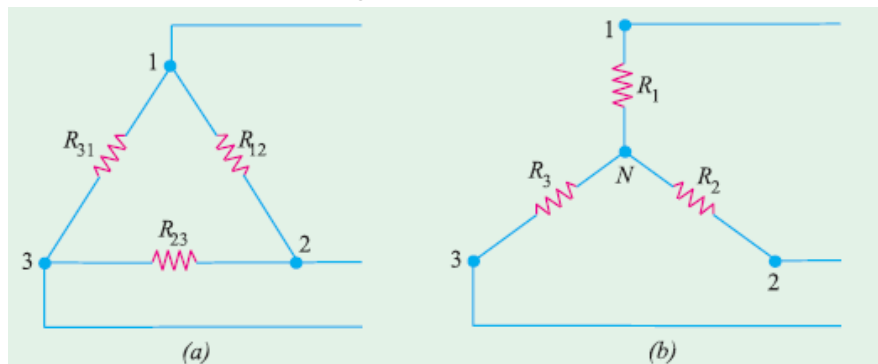

First, take delta connection : Between terminals 1 and 2, there are two parallel paths; one having a resistance of R_{12} and the other having a resistance of $(R_{12} + R_{31})$.

$$\therefore \text{Resistance between terminals 1 and 2 is} = \frac{R_{12} \times (R_{23} + R_{31})}{R_{12} + (R_{23} + R_{31})}$$

Now, take star connection : The resistance between the same terminals 1 and 2 is $(R_1 + R_2)$.

As terminal resistances have to be the same

$$\therefore R_1 + R_2 = \frac{R_{12} \times (R_{23} + R_{31})}{R_{12} + R_{23} + R_{31}} \quad \dots(i)$$

Similarly, for terminals 2 and 3 and terminals 3 and 1, we get

$$R_2 + R_3 = \frac{R_{23} \times (R_{31} + R_{12})}{R_{12} + R_{23} + R_{31}} \quad \dots(ii)$$

$$\text{and} \quad R_3 + R_1 = \frac{R_{31} \times (R_{12} + R_{23})}{R_{12} + R_{23} + R_{31}} \quad \dots(iii)$$

Now, subtracting (ii) from (i) and adding the result to (iii), we get

$$R_1 = \frac{R_{12} R_{31}}{R_{12} + R_{23} + R_{31}}; R_2 = \frac{R_{23} R_{12}}{R_{12} + R_{23} + R_{31}} \text{ and } R_3 = \frac{R_{31} R_{23}}{R_{12} + R_{23} + R_{31}}$$

How to Remember ?

It is seen from above that each numerator is the product of the two sides of the delta which meet at the point in star. Hence, it should be remembered that : resistance of each arm of the star is given by the product of the resistances of the two delta sides that meet at its end divided by the sum of the three delta resistances.

Star/Delta Transformation

This transformation can be easily done by using equations (i), (ii) and (iii) given above. Multiplying (i) and (ii), (ii) and (iii), (iii) and (i) and adding them together and then simplifying them, we get

$$R_{12} = \frac{R_1 R_2 + R_2 R_3 + R_3 R_1}{R_3} = R_1 + R_2 + \frac{R_1 R_2}{R_3}$$

$$R_{23} = \frac{R_1 R_2 + R_2 R_3 + R_3 R_1}{R_1} = R_2 + R_3 + \frac{R_2 R_3}{R_1}$$

$$R_{31} = \frac{R_1 R_2 + R_2 R_3 + R_3 R_1}{R_2} = R_1 + R_3 + \frac{R_3 R_1}{R_2}$$

How to Remember ?

The equivalent delta resistance between any two terminals is given by the sum of star resistances between those terminals plus the product of these two star resistances divide by the third star resistances.

Example 1. Find the input resistance of the circuit between the points A and B of Fig. (a).

Solution. For finding R_{AB} , we will convert the delta CDE of Fig. (a) into its equivalent star as shown in Fig. (b).

$$R_{CS} = 8 \times 4 / 18 = 16/9 \Omega \quad R_{ES} = 8 \times 6 / 18 = 24/9 \Omega \quad R_{DS} = 6 \times 4 / 18 = 12/9 \Omega$$

The two parallel resistances between S and B can be reduced to a single resistance of $35/9 \Omega$

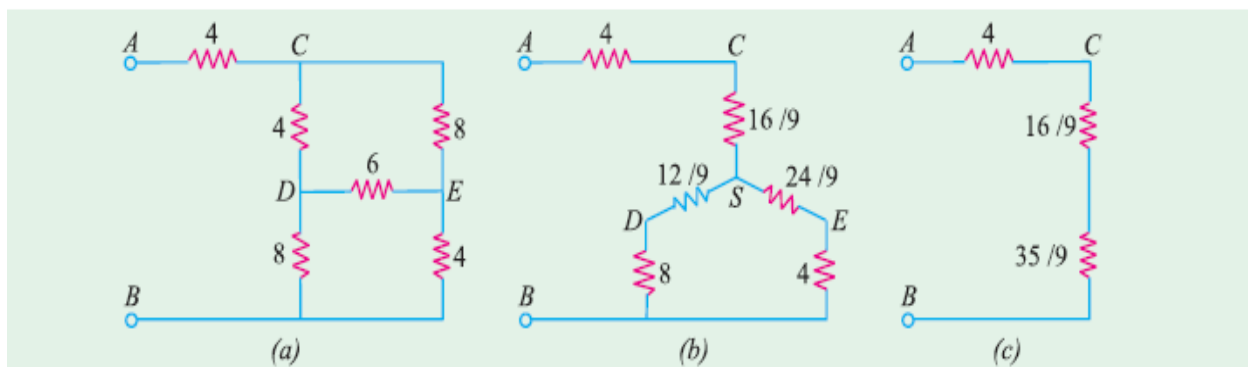

Fig

As seen from Fig. (c), $R_{AB} = 4 + (16/9) + (35/9) = 87/9 \Omega$

Example 2. A bridge network ABCD has arms AB, BC, CD and DA of resistances 1, 1, 2 and 1 ohm respectively. If the detector AC has a resistance of 1 ohm, determine by star/delta transformation, the network resistance as viewed from the battery terminals.

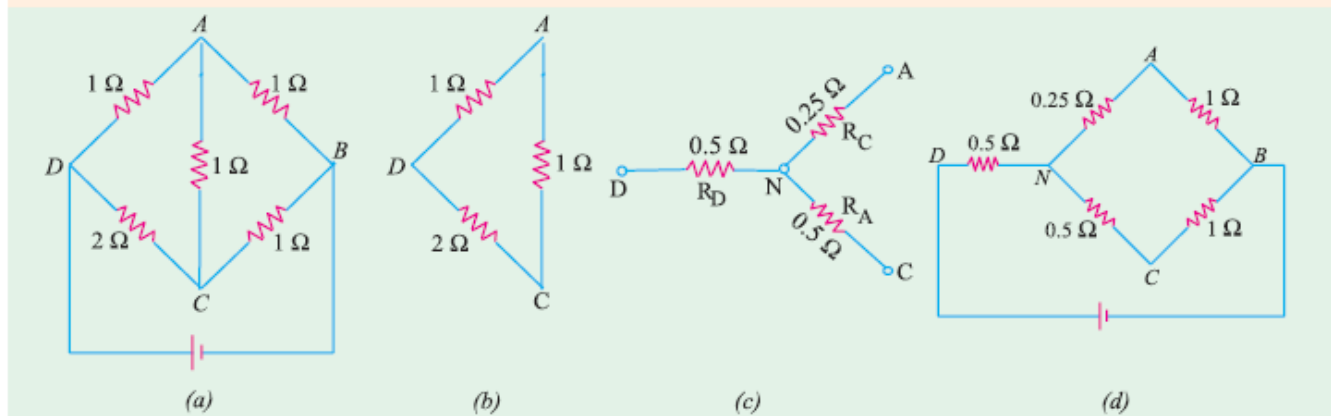

Fig.

Solution. As shown in Fig. (b), delta DAC has been reduced to its equivalent star.

$$R_D = \frac{2 \times 1}{2 + 1 + 1} = 0.5 \Omega, \quad R_A = \frac{1}{4} = 0.25 \Omega, \quad R_C = \frac{2}{4} = 0.5 \Omega$$

Hence, the original network of Fig. (a) is reduced to the one shown in Fig. (d). As seen, there are two parallel paths between points N and B, one of resistance 1.25 Ω and the other of resistance 1.5 Ω. Their combined resistance is

$$= \frac{1.25 \times 1.5}{1.25 + 1.5} = \frac{15}{22} \Omega$$

Total resistance of the network between points D and B is

$$= 0.5 + \frac{15}{22} = \frac{13}{11} \Omega$$

8) Short and Open Circuits

When two points of circuit are connected together by a wire (Fig. 1.8), they are said to be *short-circuited*. Since ‘short’ has practically zero resistance, it gives two important facts :

- (i) No voltage can exist across it because $V = IR = I \times 0 = 0$
- (ii) Current through it (called short-circuit current) is very large (theoretically, infinity)

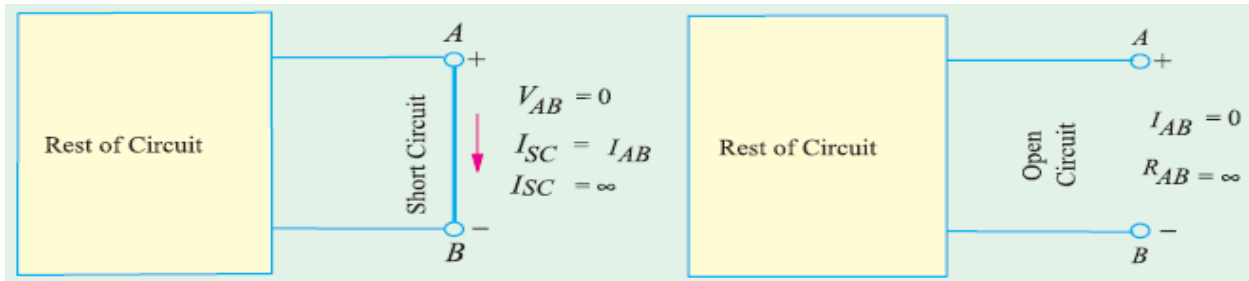

Fig. 1. 8

Fig. 1. 9

Two points are said to be open-circuited when there is no connection between them (Fig.1.9). Obviously, an ‘open’ represents a break in the continuity of the circuit. Due to this break

- (i) resistance between the two points is infinite.
- (ii) there is no flow of current between the two points.

Division of Current in Parallel Circuits

In Fig. 1.10, two resistances are joined in parallel across a voltage V . The current in each branch, as given in Ohm’s law, is

$$I_1 = V/R_1 \text{ and } I_2 = V/R_2$$

$$\therefore \frac{I_1}{I_2} = \frac{R_2}{R_1}$$

As $\frac{I}{R_1} = G_1 \text{ and } \frac{I}{R_2} = G_2$

$$\therefore \frac{I_1}{I_2} = \frac{G_1}{G_2}$$

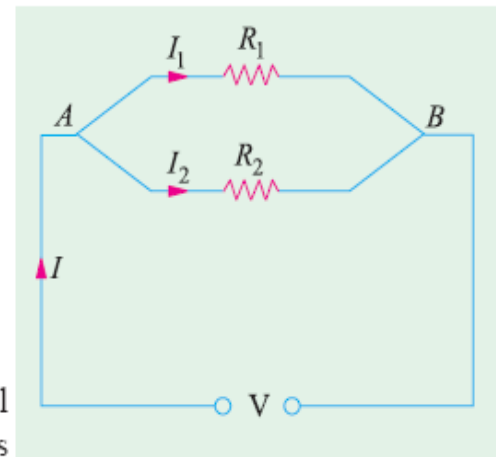

Fig. 1.10.

Hence, the division of current in the branches of a parallel circuit is directly proportional to the conductance of the branches or inversely proportional to their resistances. We may also express the branch currents in terms of the total circuit current thus :

Now $I_1 + I_2 = I; \therefore I_2 = I - I_1 \therefore \frac{I_1}{I - I_1} = \frac{R_2}{R_1} \text{ or } I_1 R_1 = R_2 (I - I_1)$

$$\therefore I_1 = I \frac{R_2}{R_1 + R_2} = I \frac{G_1}{G_1 + G_2} \text{ and } I_2 = I \frac{R_1}{R_1 + R_2} = I \frac{G_2}{G_1 + G_2}$$

Take the case of three resistors in parallel connected across a voltage V (Fig. 1.11). Total current is $I = I_1 + I_2 + I_3$. Let the equivalent resistance be R . Then

$$V = IR$$

Also $V = I_1 R_1 \therefore IR = I_1 R_1$

or $\frac{I}{I_1} = \frac{R_1}{R}$ or $I_1 = IR/R_1 \dots(i)$

Now $\frac{I}{R} = \frac{I}{R_1} + \frac{I}{R_2} + \frac{I}{R_3}$

$$R = \frac{R_1 R_2 R_3}{R_2 R_3 + R_2 R_1 + R_1 R_3}$$

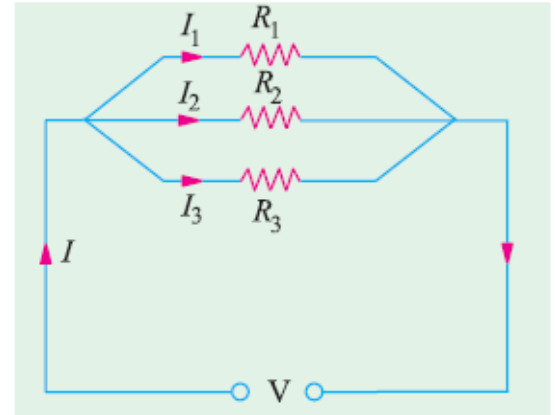

(Fig. 1.11)

From (i) above, $I_1 = I \left(\frac{R_2 R_3}{R_1 R_2 + R_2 R_3 + R_3 R_1} \right) = I \cdot \frac{G_1}{G_1 + G_2 + G_3}$

Similarly, $I_2 = I \frac{R_1 R_3}{R_1 R_2 + R_2 R_3 + R_3 R_1} = I \cdot \frac{G_2}{G_1 + G_2 + G_3}$

$$I_3 = I \frac{R_1 R_2}{R_1 R_2 + R_2 R_3 + R_3 R_1} = I \cdot \frac{G_3}{G_1 + G_2 + G_3}$$

Example 2. A resistance of 10Ω is connected in series with two resistances each of 15Ω arranged in parallel. What resistance must be connected across this parallel combination so that the total current taken shall be 1.5 A with 20 V applied ?

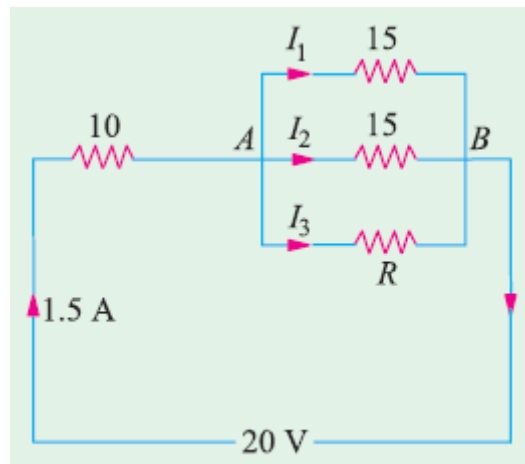

Fig. 1.12

Solution. The circuit connections are shown in Fig. 1.12.

Drop across $10\text{-}\Omega$ resistor = $1.5 \times 10 = 15 \text{ V}$

Drop across parallel combination, $V_{AB} = 20 - 15 = 5 \text{ V}$

Hence, voltage across each parallel resistance is 5 V .

$I_1 = 5/15 = 1/3 \text{ A}$, $I_2 = 5/15 = 1/3 \text{ A}$

$$I_3 = 1.5 - (1/3 + 1/3) = 5/6 \text{ A}$$

$$\therefore \frac{1}{3} R = 5 \text{ or } (5/6) R = 5 \text{ or } R = 6 \Omega.$$

Example 3. Determine the value of R and current through it in Fig. 1.7, if current through branch AO is zero.

Solution. The given circuit can be redrawn as shown in Fig. 1.7 (b). As seen, it is nothing else but Wheatstone bridge circuit. As is well-known, when current through branch AO becomes zero, the bridge is said to be balanced. In that case, products of the resistances of opposite arms of the bridge become equal.

$$\therefore 4 \times 1.5 = R \times 1; R = 6 \Omega$$

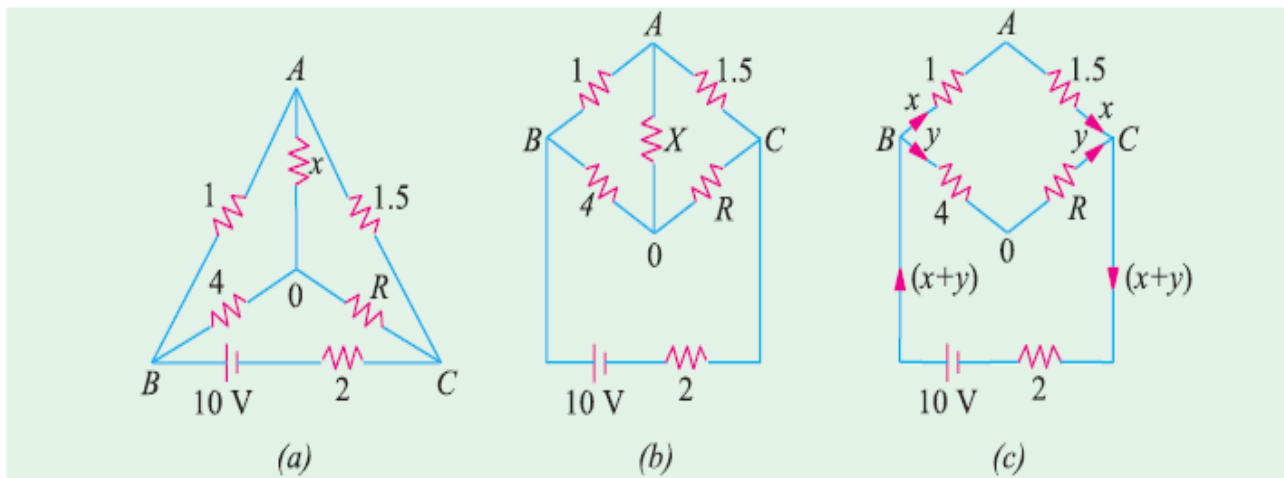

Fig.1.7.

Under condition of balance, it makes no difference if resistance X is removed thereby giving us the circuit of Fig. 1.7 (c). Now, there are two parallel paths between points B and C of resistances $(1 + 1.5) = 2.5 \Omega$ and $(4 + 6) = 10 \Omega$. $R_{BC} = 10 \parallel 2.5 = 2 \Omega$

Total circuit resistance = $2 + 2 = 4 \Omega$. Total circuit current = $10/4 = 2.5 \text{ A}$

This current gets divided into two parts at point B . Current through R is

$$y = 2.5 \times 2.5/12.5 = \mathbf{0.5 \text{ A}}$$

9)Kirchhoff's Laws

Kirchhoff's laws, two in number, are particularly useful

- (a) in determining the equivalent resistance of a complicated network and
- (b) for calculating the currents flowing in the various elements.

The two-laws are :

1. Kirchhoff's Current Law (KCL)

It states as follows :

in any electrical network, the algebraic sum of the currents meeting at a point (or junction) is zero.

But in another way, it simply means that the total current **leaving** a junction is equal to the total current **entering** that junction.

Consider the case of a few conductors meeting at a point A as in Fig. 1.14 (a). Some conductors have currents leading to point A, whereas some have currents leading away from point A. Assuming the **incoming currents to be positive** and the **outgoing currents negative**, we have

$$I_1 + (-I_2) + (-I_3) + (+I_4) + (-I_5) = 0$$

or $I_1 + I_4 - I_2 - I_3 - I_5 = 0$ or $I_1 + I_4 = I_2 + I_3 + I_5$

incoming currents = outgoing currents

Similarly, in Fig. 1.14 (b) for node A

$$+I + (-I_1) + (-I_2) + (-I_3) + (-I_4) = 0 \text{ or } I = I_1 + I_2 + I_3 + I_4$$

We can express the above conclusion thus : $\Sigma I = 0$ at a junction

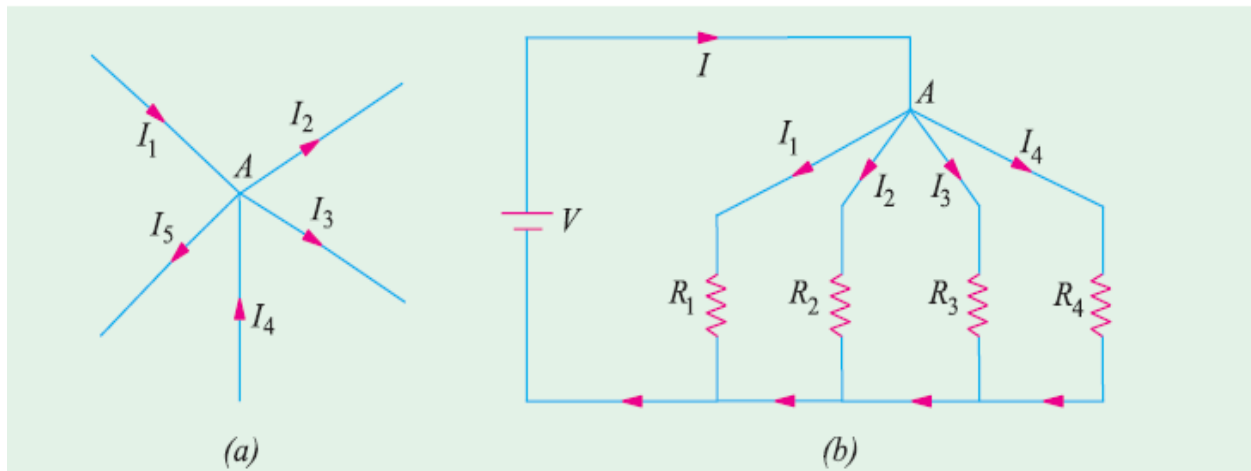

Fig.1.14

2. Kirchhoff's Voltage Law (KVL)

It states as follows :

The algebraic sum of the products of currents and resistances in each of the conductors in any closed path (or mesh) in a network plus the algebraic sum of the e.m.fs. in that path is zero.

In other words,

$$\Sigma IR + \Sigma e.m.f. = 0$$

...round a mesh

It should be noted that algebraic sum is the sum which takes into account the polarities of the voltage drops.

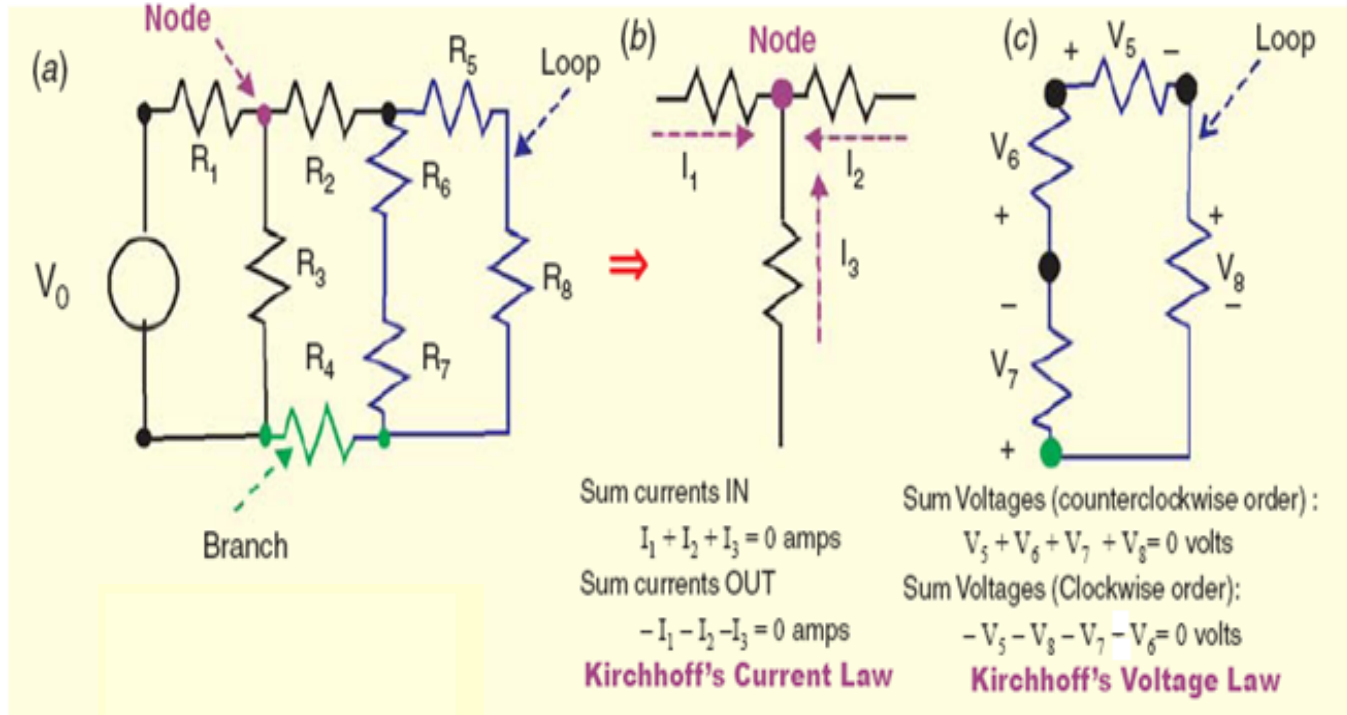

10)Determination of Voltage Sign

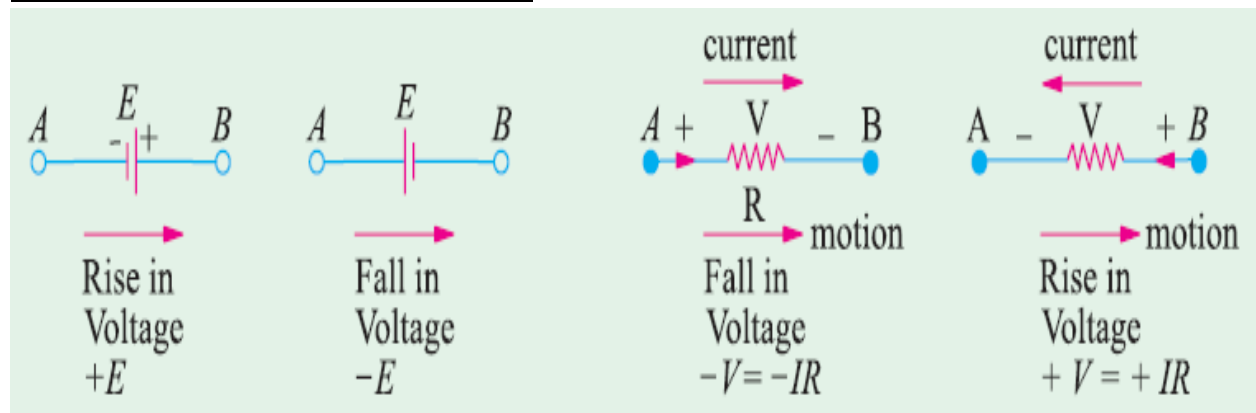

Consider the closed path ABCDA in Fig. below. As we travel around the mesh in the clockwise direction, different voltage drops will have the following signs :

- $I_1 R_1$ is -ve (fall in potential)
- $I_2 R_2$ is -ve (fall in potential)
- $I_3 R_3$ is +ve (rise in potential)
- $I_4 R_4$ is -ve (fall in potential)
- E_2 is -ve (fall in potential)
- E_1 is +ve (rise in potential)

Using Kirchhoff's voltage law, we get

$$-I_1 R_1 - I_2 R_2 + I_3 R_3 - I_4 R_4 - E_2 + E_1 = 0$$

or $I_1 R_1 + I_2 R_2 - I_3 R_3 + I_4 R_4 = E_1 - E_2$

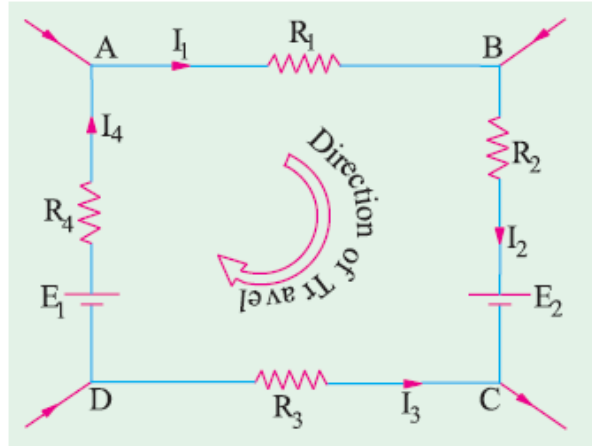

Example 4. Determine the currents in the unbalanced bridge circuit of Fig. 1.16 below. Also, determine the p.d. across BD and the resistance from B to D.

Solution. Assumed current directions are as shown in Fig. 1.16. Applying Kirchhoff's Second Law to circuit DACD, we get

$$-x - 4z + 2y = 0 \text{ or } x - 2y + 4z = 0 \quad \dots(1)$$

Circuit ABCA gives

$$-2(x - z) + 3(y + z) + 4z = 0 \text{ or } 2x - 3y - 9z = 0 \quad \dots(2)$$

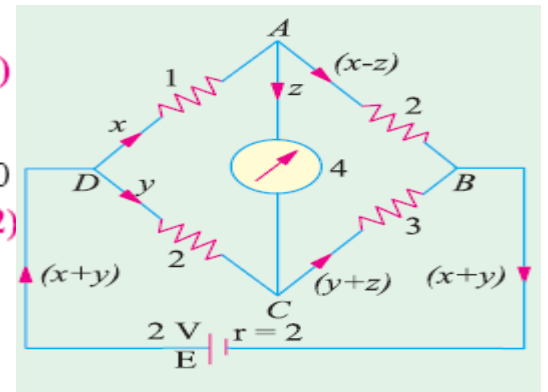

Fig. 1.16
... (3)

Circuit DABED gives

$$-x - 2(x - z) - 2(x + y) + 2 = 0 \text{ or } 5x + 2y - 2z = 2 \quad \dots(3)$$

Multiplying (1) by 2 and subtracting (2) from it, we get

$$-y + 17z = 0 \quad \dots(4)$$

Similarly, multiplying (1) by 5 and subtracting (3) from it, we have

$$-12y + 22z = -2 \text{ or } -6y + 11z = -1 \quad \dots(5)$$

Eliminating y from (4) and (5), we have $91z = 1$ or $z = 1/91$ A

From (4); $y = 17/91$ A. Putting these values of y and z in (1), we get $x = 30/91$ A

Current in DA = $x = 30/91$ A Current in DC = $y = 17/91$ A

Current in $AB = x - z = \frac{30}{91} - \frac{1}{91} = \frac{29}{91}$ A

Current in $CB = y + z = \frac{17}{91} + \frac{1}{91} = \frac{18}{91}$ A

Current in external circuit = $x + y = \frac{30}{91} + \frac{17}{91} = \frac{47}{91}$ A

Current in $AC = z = 1/91 \text{ A}$

Internal voltage drop in the cell = $2(x + y) = 2 \times 47/91 = 94/91 \text{ V}$

\therefore P.D. across points D and $B = 2 - \frac{94}{91} = \frac{88}{91} \text{ V}$

Equivalent resistance of the bridge between points D and B

$= \frac{\text{p.d. between points } B \text{ and } D}{\text{current between points } B \text{ and } D} = \frac{88/91}{47/91} = \frac{88}{47} = 1.87 \Omega \text{ (approx)}$

Exp5: Applying Kirchhoff's laws to different loops in Fig. 1.17, find the values of V_1 and V_2 .

Solution. Starting from point A and applying Kirchhoff's voltage law to loop No.3, we get

$-V_3 + 5 = 0$ or $V_3 = 5 \text{ V}$

Starting from point A and applying Kirchhoff's voltage law to loop No. 1, we get

$10 - 30 - V_1 + 5 = 0$ or $V_1 = -15 \text{ V}$

The negative sign of V_1 denotes that its polarity is opposite to that shown in the figure.

Starting from point B in loop No. 3, we get

$-(-15) - V_2 + (-15) = 0$ or $V_2 = 0$

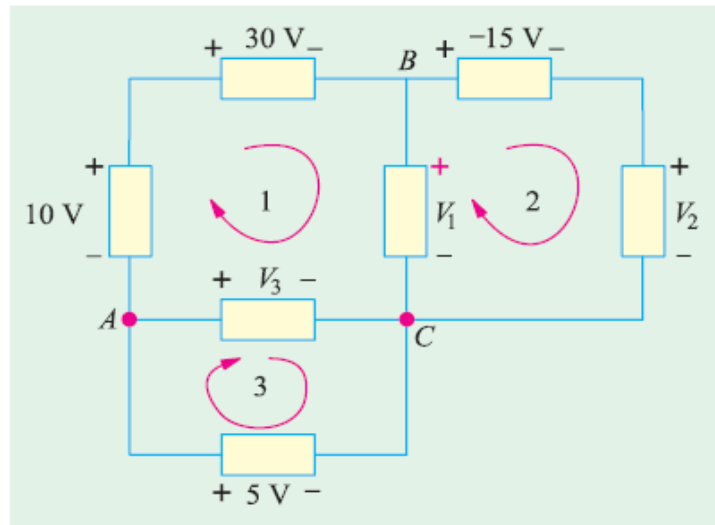

Fig.1.17.

Superposition Theorem

This theorem stated as follows :

In a linear network containing more than one source, the current which flows at any point is the sum of all the currents which would flow at that point if each source were considered separately and all the other sources replaced by resistances equal to their internal resistances.

Explanation

In Fig. 1.18 (a) I_1 , I_2 and I represent the values of currents which are due to the

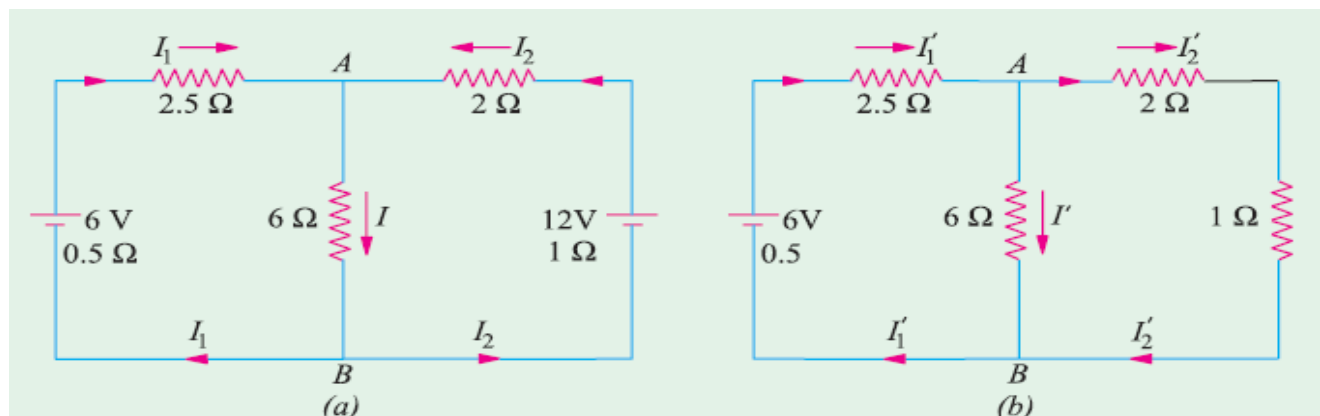

simultaneous action of the two sources of e.m.f. in the network. In Fig. 1.18 (b) are shown the current values which would have been obtained if left-hand side battery had acted alone. Similarly, Fig. 1.19 represents conditions obtained when right-hand side battery acts alone. By combining the current values of Fig. 1.18 (b) and 1.19 the actual values of Fig. 1.18 (a) can be obtained.

Obviously, $I_1 = I_1' - I_1''$, $I_2 = I_2'' - I_2'$, $I = I' + I''$.

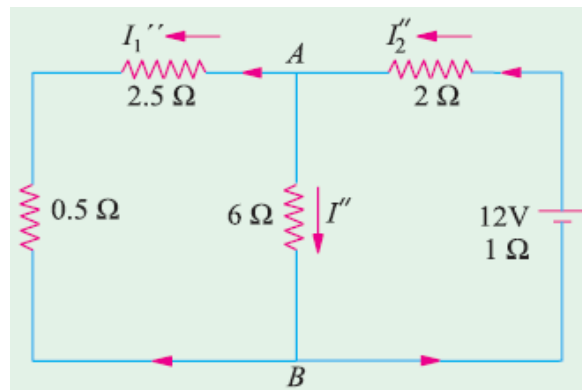

Fig. 1.19.

Example 6. In Fig. 1.18 (a) let battery e.m.f.s. be 6 V and 12 V with their internal resistances 0.5 Ω and 1 Ω. The values of other resistances are as indicated. Find the different currents flowing in the branches and voltage across 6 ohm resistor.

Solution. In Fig. 1.18 (b), 12-volt battery has been removed though its internal resistance of 1 Ω remains. The various currents can be found by applying Ohm's Law. It is seen that there are two parallel paths between points A and B, having resistances of 6 Ω and $(2 + 1) = 3$ Ω.

$$\therefore \text{equivalent resistance} = 3 \parallel 6 = 2 \Omega$$

$$\text{Total resistance} = 0.5 + 2.5 + 2 = 5 \Omega \therefore I_1' = 6/5 = \mathbf{1.2 \text{ A}}$$

This current divides at point A in the ratio of the resistances of the two parallel paths.

$$\therefore I' = 1.2 \times (3/9) = 0.4 \text{ A. Similarly, } I_2' = 1.2 \times (6/9) = 0.8 \text{ A}$$

In Fig. 1.19, 6 volt battery has been removed but not its internal resistance. The various currents and their directions are as shown. The equivalent resistance to the left to points A and B is $= 3 \parallel 6 = 2 \Omega$

$$\therefore \text{total resistance} = 1 + 2 + 2 = 5 \Omega \therefore I_2'' = 12/5 = 2.4 \text{ A}$$

At point A, this current is divided into two parts,

$$I'' = 2.4 \times 3/9 = 0.8 \text{ A, } I_1'' = 2.4 \times 6/9 = 1.6 \text{ A}$$

The actual current values of Fig. 1.18 (a) can be obtained by superposition of these two sets of current values.

$$\therefore I_1 = I_1' - I_1'' = 1.2 - 1.6 = -0.4 \text{ A}$$

$$I_2 = I_2'' - I_2' = 2.4 - 0.8 = 1.6 \text{ A}$$

$$I = I' + I'' = 0.4 + 0.8 = 1.2 \text{ A}$$

$$\text{Voltage drop across 6-ohm resistor} = 6 \times 1.2 = 7.2 \text{ V}$$

Thevenin Theorem

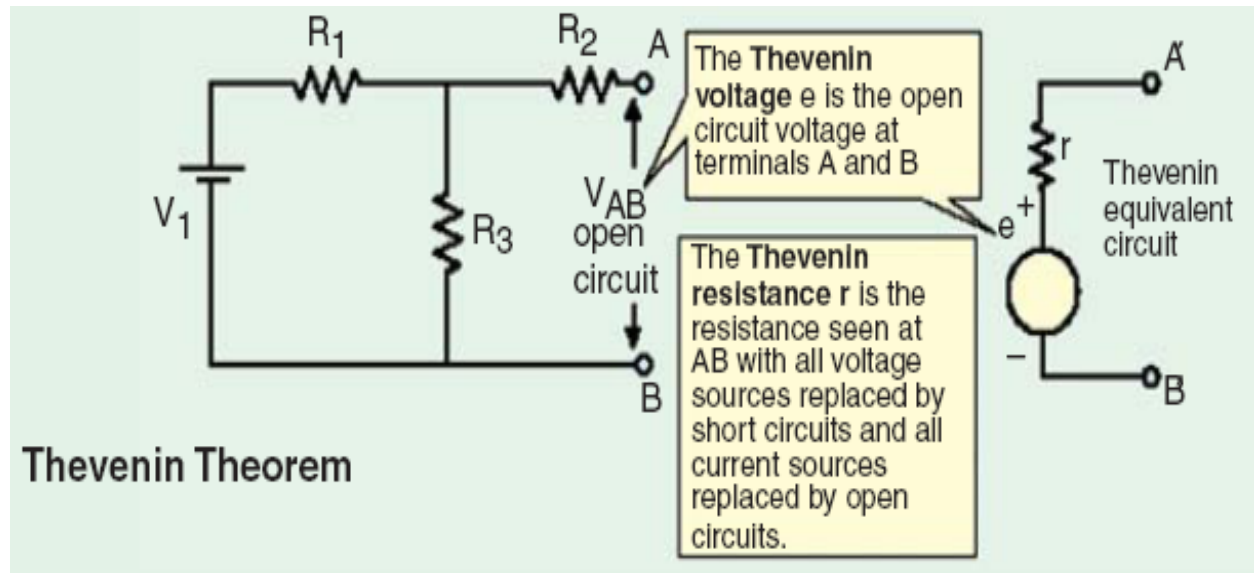

It provides a mathematical technique for replacing a given network, as viewed from two output terminals, by a single voltage source with a series resistance. It makes the solution of complicated networks (particularly, electronic networks) quite quick and easy. The application of this extremely useful theorem will be explained with the help of the following simple example.

Suppose, it is required to find current flowing through load resistance R_L , as shown in Fig. 1.20(a). We will proceed as under :

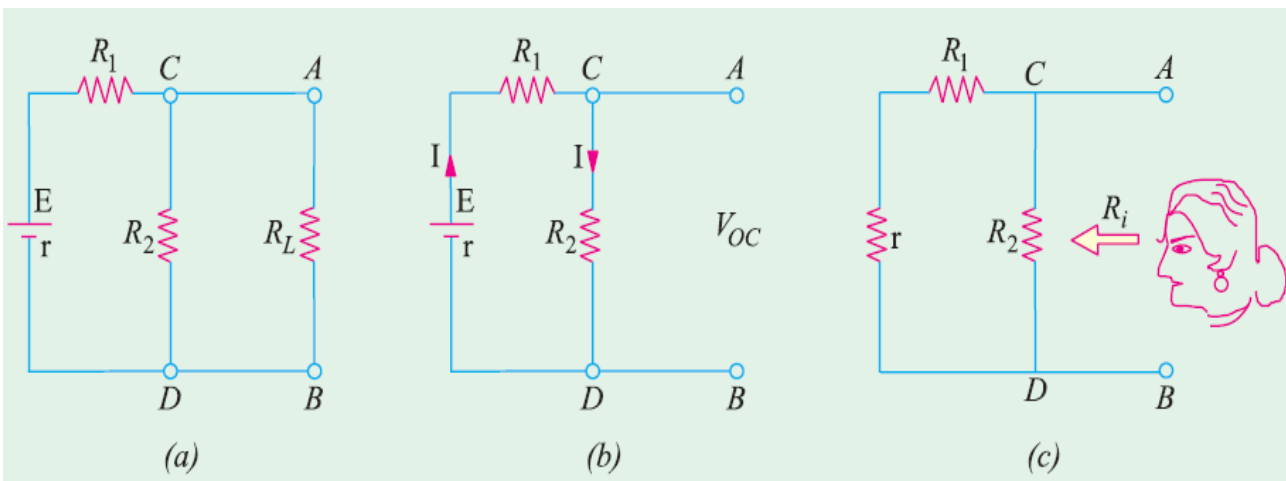

1. Remove R_L from the circuit terminals A and B and redraw the circuit as shown in Fig. 1.20 (b). Obviously, the terminals have become open-circuited.
2. Calculate the open-circuit voltage V_{oc} which appears across terminals A and B when they are open *i.e.* when R_L is removed. As seen, $V_{oc} = \text{drop across } R_2 = IR_2$ where I is the circuit current when A and B are open.

$$I = \frac{E}{R_1 + R_2 + r} \quad \therefore V_{oc} = IR_2 = \frac{ER_2}{R_1 + R_2 + r} \quad [r \text{ is the internal resistance of battery}]$$

It is also called 'Thevenin voltage' V_{th} .

3. Now, imagine the battery to be removed from the circuit, leaving its internal resistance r behind and redraw the circuit, as shown in Fig. 1.20 (c). When viewed **inwards** from terminals A and B , the circuit consists of two parallel paths : one containing R_2 and the other containing $(R_1 + r)$. The equivalent resistance of the network, as viewed from these terminals is given as:

$$R = R_2 \parallel (R_1 + r) = \frac{R_2(R_1 + r)}{R_2 + (R_1 + r)}$$

This resistance is also called ,Thevenin resistance R_{th} (though, it is also sometimes written as R_i). Consequently, as viewed from terminals A and B , the whole network (excluding R_L) can be reduced to a single source (called Thevenin's source) whose e.m.f. equals V_{oc} (or V_{th}) and whose internal resistance equals R_{th} (or R_i) as shown in Fig. 1.21.

4. R_L is now connected back across terminals A and B from where it was temporarily removed earlier. Current flowing through R_L is given by:

$$I = \frac{V_{th}}{R_{th} + R_L}$$

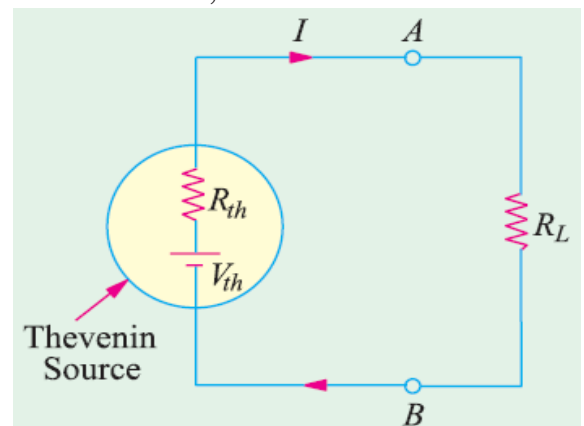

It is clear from above that any network of resistors and voltage sources (and current sources as well) when viewed from any points A and B in the network, can be replaced by a single voltage source and a single resistance in series with the voltage source. After this replacement of the network by a single voltage source with a series resistance has been accomplished, it is easy to find current in any load resistance joined across terminals A and B .

How to Thevenize a Given Circuit ?

1. Temporarily remove the resistance (called load resistance R_L) whose current is required.
2. Find the open-circuit voltage V_{oc} which appears across the two terminals from where resistance has been removed. It is also called Thevenin voltage V_{th} .
3. Compute the resistance of the whole network as looked into from these two terminals after all voltage sources have been removed leaving behind their internal resistances (if any) and current sources have been replaced by open-circuit *i.e.* infinite resistance. It is also called Thevenin resistance R_{th} or R_i .
4. Replace the entire network by a single Thevenin source, whose voltage is V_{th} or V_{oc} and whose internal resistance is R_{th} or R_i .
5. Connect R_L back to its terminals from where it was previously removed.
6. Finally, calculate the current flowing through R_L by using the equation:
 $I = V_{th}/(R_{th} + R_L)$ or $I = V_{oc}/(R_i + R_L)$.

Exp.7. Apply Thevenin's theorem to calculate the current through the $4\ \Omega$ resistor of the circuit of Fig. 1.22 (a).

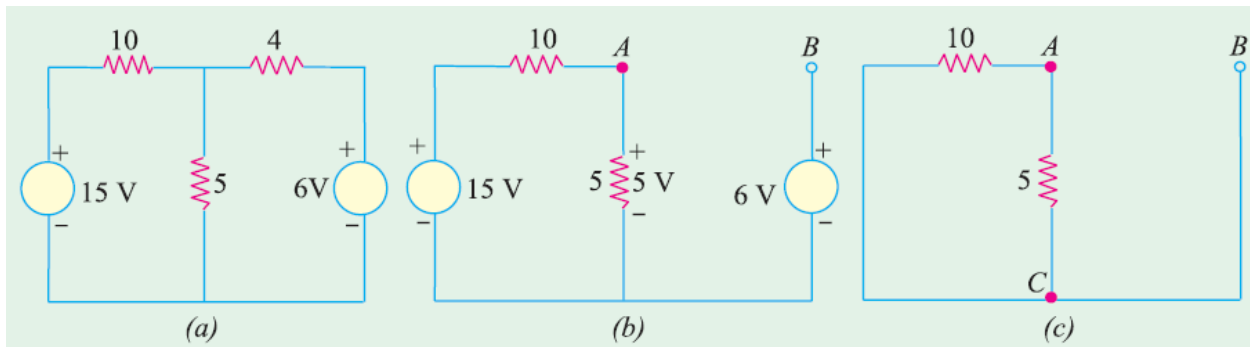

Solution. As shown in Fig. 1.22 (b), $4\ \Omega$ resistance has been removed thereby open-circuiting the terminals A and B. We will now find V_{AB} and R_{AB} which will give us V_{th} and R_{th} respectively. The potential drop across $5\ \Omega$ resistor can be found with the help of voltage-divider rule. Its value is

$= 15 \times 5/(5 + 10) = 5\ \text{V}$. For finding V_{AB} , we will go from point B to point A in the clockwise direction and find the algebraic sum of the voltages met on the way.

$$\therefore V_{AB} = -6 + 5 = -1\ \text{V}.$$

It means that point A is negative with respect to point B, or point B is at a higher potential than point A by one volt. In Fig. 1.22(c), the two voltage

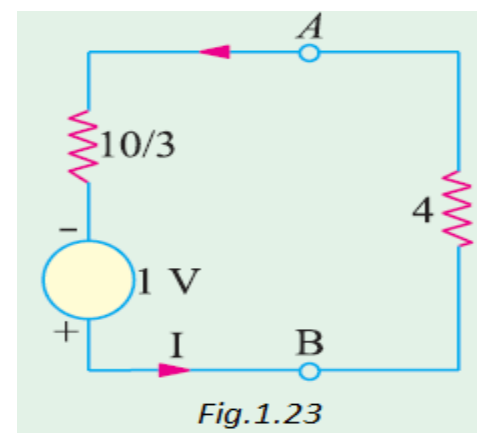

Fig.1.23

source have been short circuited. The resistance of the network as viewed from points A and B is the same as viewed from points A and C.

$$\therefore R_{AB} = R_{AC} = 5 \parallel 10 = 10/3 \Omega$$

Thevenin's equivalent source is shown in Fig. 1.23 above in which 4Ω resistor has been joined back across terminals A and B. Polarity of the voltage source is marked.

$$\therefore I = \frac{1}{(10/3) + 4} = \frac{3}{22} = 0.136 \text{ A} \quad \text{From B to A}$$

Norton's Theorem

This theorem is an alternative to the Thevenin's theorem. In fact, it is the dual of Thevenin's theorem. Whereas Thevenin's theorem reduces a two-terminal active network to an equivalent constant-voltage source and series resistance, Norton's theorem replaces the network by an equivalent constant-current source and a parallel resistance.

Explanation

As seen from Fig.1.24 (a), a short is placed across the terminals A and B of the network *with all its energy sources present*. The short-circuit current I_{SC} gives the value of constant-current source.

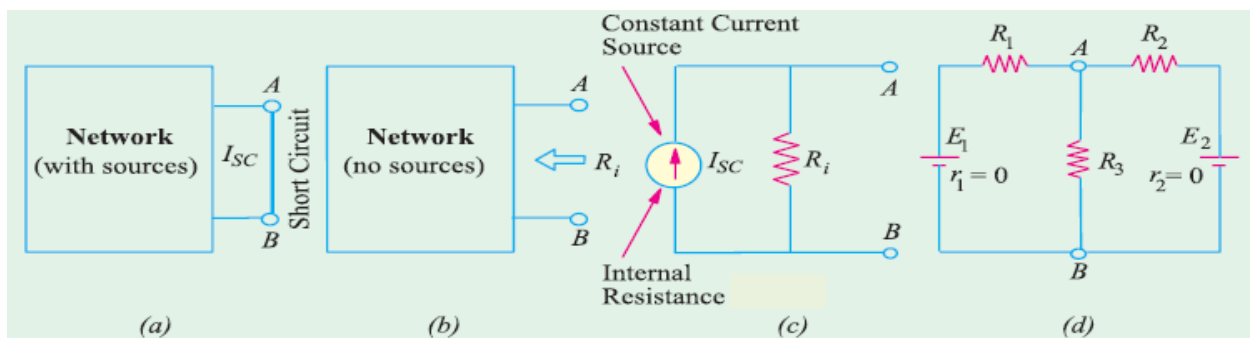

For finding R_i , all sources have been removed as shown in Fig.1.24 (b). The resistance of the network when looked into from terminals A and B gives R_i .

The Norton's equivalent circuit is shown in Fig.1.24(c). It consists of an ideal constant current source of internal resistance with a resistance R_i connected in parallel with it.

Norton's theorem stated as follows :

The voltage between any two points in a network is equal to $(I_{SC} \cdot R_i)$ where I_{SC} is the short circuit current between the two points and R_i is the resistance of the

network as viewed from these points with all voltage sources being replaced by their internal resistances (if any) and current sources replaced by open-circuits.

Suppose, it is required to find the voltage across resistance R_3 and hence current through it [Fig. 1.24 (d)]. If short-circuit is placed between A and B, then current in it due to battery of e.m.f. E_1 is E_1/R_1 and due to the other battery is E_2/R_2 .

$$\therefore I_{SC} = \frac{E_1}{R_1} + \frac{E_2}{R_2} = E_1 G_1 + E_2 G_2$$

where G_1 and G_2 are branch conductances. Now, the internal resistance of the network as viewed from A and B simply consists of resistances R_1 and R_2 connected in parallel between A and B.

$$\begin{aligned} \therefore \frac{1}{R_i} &= \frac{1}{R_1} + \frac{1}{R_2} = G_1 + G_2 \\ \therefore R_i &= \frac{1}{G_1 + G_2} \end{aligned} \quad \therefore V_{AB} = I_{SC} \cdot R_i$$

Current through R_2 is $I_3 = V_{AB}/R_3$.

How To Nortonize a Given Circuit ?

1. Remove the resistance across the two given terminals and put a short-circuit across them.
2. Compute the short-circuit current I_{SC} .
3. Remove all voltage sources but retain their internal resistances, if any. Similarly, remove all current sources and replace them by open-circuits *i.e.* by infinite resistance.
4. Next, find the resistance R_i which called R_N of the network as looked into from the given terminals. It is exactly the same as R_{th} .
5. The current source (I_{SC}) joined in parallel with R_i between the two terminals gives Norton's equivalent circuit.

Exp8. Using Norton's theorem, find the current equivalent of the circuit shown in Fig. 1.25(a).

Solution.

When terminals A and B are short-circuited as shown in Fig. 1.25 (b), total resistance of the circuit, as seen by the battery, consists of a 10 Ω resistance in series with a parallel combination of 10 Ω and 15 Ω resistances.

$$\therefore \text{ total resistance} = 10 + \frac{15 \times 10}{15 + 10} = 16 \Omega$$

$$\therefore \text{ battery current } I = 100/16 = 6.25 \text{ A}$$

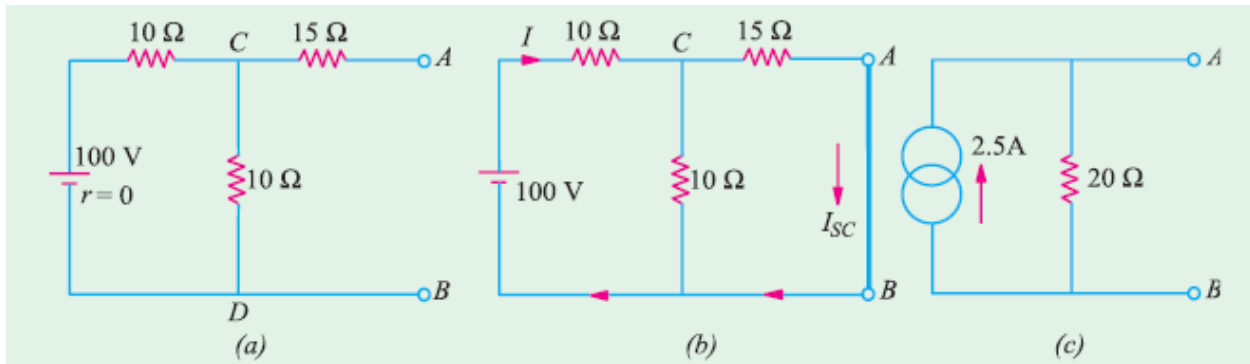

This current is divided into two parts at point C of Fig. 1.25 (b). Current through A B is $I_{SC} = 6.25 \times 10/25 = 2.5 \text{ A}$

Since the battery has no internal resistance, the input resistance of the network when viewed from A and B consists of a 15 Ω resistance in series with the parallel combination of 10 Ω and 10 Ω.

$$\text{Hence, } R_i = 15 + (10/2) = 20 \Omega$$

Hence, the equivalent current source is shown as in Fig. 1.25(c).

Maximum Power Transfer Theorem

A resistive load will abstract maximum power from a network when the load resistance is equal to the resistance of the network as viewed from the output terminals, with all energy sources removed leaving behind their internal resistances. In Fig.1.26, a load resistance of R_L is connected across the terminals A and B of a network which consists of a generator of e.m.f. E and internal resistance R_g and a series resistance R which, in fact, represents the resistance of the connecting wires.

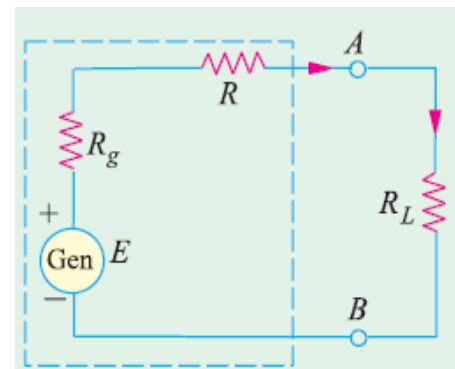

Let $R_i = R_g + R =$ internal resistance of the network as viewed from A and B. According to this theorem, R_L will abstract maximum power from the network when $R_L = R_i$.

Proof. Circuit current
$$I = \frac{E}{R_L + R_i}$$

Power consumed by the load is

$$P_L = I^2 R_L = \frac{E^2 R_L}{(R_L + R_i)^2} \quad \dots(i)$$

For P_L to be maximum, $\frac{dP_L}{dR_L} = 0$.

Differentiating Eq. (i) above, we have

$$\frac{dP_L}{dR_L} = E^2 \left[\frac{1}{(R_L + R_i)^2} + R_L \left(\frac{-2}{(R_L + R_i)^3} \right) \right] = E^2 \left[\frac{1}{(R_L + R_i)^2} - \frac{2R_L}{(R_L + R_i)^3} \right]$$

$$\therefore 0 = E^2 \left[\frac{1}{(R_L + R_i)^2} - \frac{2R_L}{(R_L + R_i)^3} \right] \quad \text{or} \quad 2R_L = R_L + R_i \quad \text{or} \quad R_L = R_i$$

$$\therefore \text{Max. power is } P_{L \max.} = \frac{E^2 R_L}{4 R_L^2} = \frac{E^2}{4 R_L} = \frac{E^2}{4 R_i}$$

Exp9. In the network shown in Fig. 1.27 (a), find the value of R_L such that maximum possible power will be transferred to R_L . Find also the value of the maximum power and the power supplied by source under these conditions.

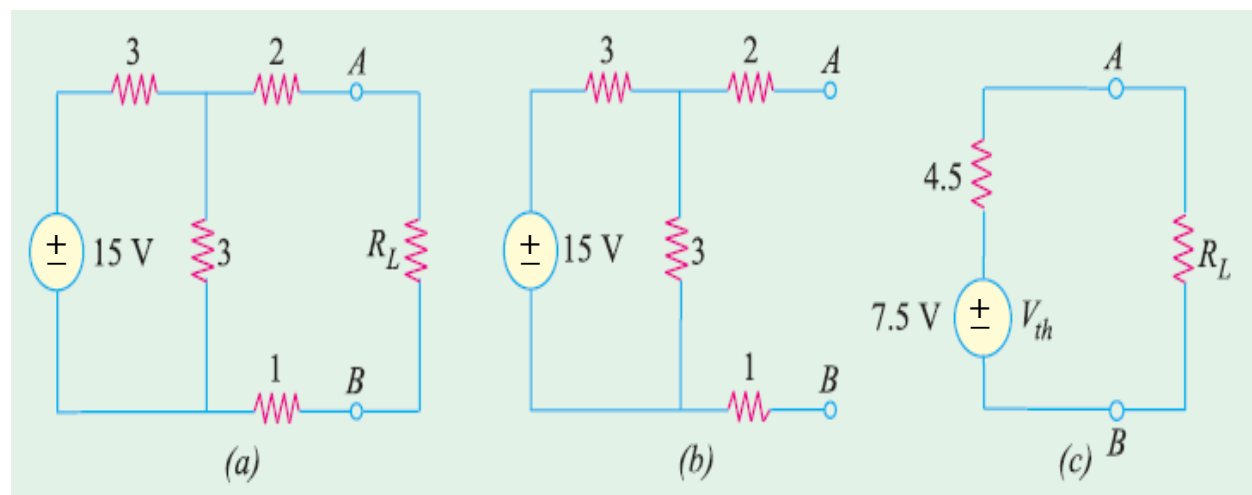

Solution:

We will remove R_L and find the equivalent Thevenin's source for the circuit to the left of terminals A and B . As seen from Fig. 1.27(b) V_{th} equals the drop across the resistor 3Ω because no current flows through 2Ω and 1Ω resistors.

Since 15 V drops across two series resistors of 3Ω each,
 $V_{th} = 15/2 = 7.5\text{ V}$.

Thevenin's resistance can be found by replacing 15 V source with a short-circuit. As seen from Fig. 1.27(b), $R_{th} = 2 + (3 \parallel 3) + 1 = 4.5\Omega$. Maximum power transfer to the load will take place when $R_L = R_{th} = 4.5\Omega$.

Maximum power drawn by $R_L = V_{th}^2/4 \times R_L = 7.5^2/4 \times 4.5 = 3.125\text{ W}$.

Since same power is developed in R_{th} , power supplied by the source $= 2 \times 3.125 = 6.250\text{ W}$.

Power Transfer Efficiency

If P_L is the power supplied to the load and P_T is the total power supplied by the voltage source, then power transfer efficiency is given by $\eta = P_L/P_T$.

Now, the generator or voltage source E supplies power to both the load resistance R_L and to the internal resistance $R_i = (R_g + R)$.

$$P_T = P_L + P_i \text{ or } E \times I = I^2 R_L + I^2 R_i$$

$$\therefore \eta = \frac{P_L}{P_T} = \frac{I^2 R_L}{I^2 R_L + I^2 R_i} = \frac{R_L}{R_L + R_i} = \frac{1}{1 + (R_i/R_L)}$$

The variation of η with RL is shown in Fig. 1.28. The maximum value of η is unity when $RL = \infty$ and has a value of 0.5 when $RL = Ri$. It means that under maximum power transfer conditions, the power transfer efficiency is only 50%.

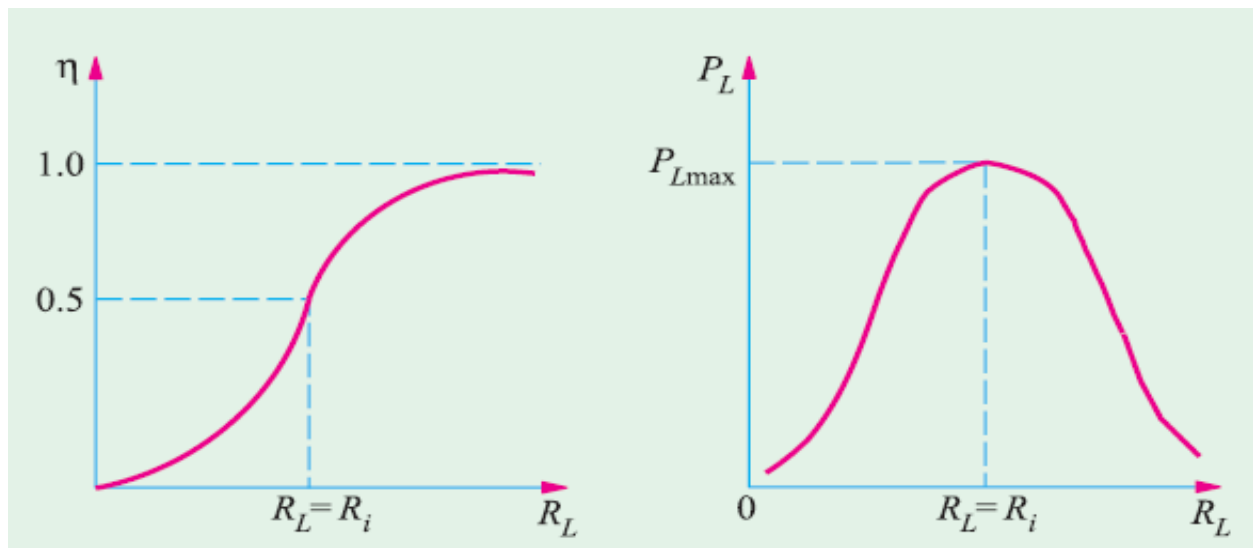

Often, a compromise has to be made between the load power and the power transfer efficiency. For example, if we make $R_L = 2 R_i$, then $P_L = 0.125 E^2/R_i$ and $\eta = 0.667$.

It is seen that the power transfer efficiency has improved from 0.5 to 0.667 *i.e.* by 33%.

Work, Power and Energy

Effect of Electric Current

It is a matter of common experience that a conductor, when carrying current, becomes hot after some time. As explained earlier, an electric current is just a directed flow or drift of electrons through a substance. The moving electrons as they pass through molecules of atoms of that substance, collide with other electrons. This electronic collision results in the production of heat. This explains why passage of current is always accompanied by generation of heat.

Joule's Law of Electric Heating

The amount of work required to maintain a current of I amperes through a resistance of R ohm for t second is

$$\begin{aligned} \text{W.D.} &= I^2 R t \text{ joules} && (\because R = V/I) \\ &= V I t \text{ joules} && (\because W = VI) \\ &= W t \text{ joules} && (\because I = V/R) \\ &= V^2 t / R \text{ joules} \end{aligned}$$

This work is converted into heat and is dissipated away. The amount of heat produced is

$$H = \frac{\text{work done}}{\text{mechanical equivalent of heat}} = \frac{W.D.}{J}$$

where $J = 4,186 \text{ joules/kcal} = 4,200 \text{ joules / kcal (approx)}$
 $\therefore H = I^2 R t / 4,200 \text{ kcal} = V I t / 4,200 \text{ kcal}$
 $= W t / 4,200 \text{ kcal} = V^2 t / 4,200 R \text{ kcal}$

Thermal Efficiency

It is defined as the ratio of the heat actually utilized to the total heat produced electrically. Consider the case of the electric kettle used for boiling water. Out of the total heat produced (i) some goes to heat the apparatus itself *i.e.* kettle (ii) some is lost by radiation and convection etc. and (iii) the rest is utilized for heating the water. Out of these, the heat utilized for useful purpose is that in (iii). Hence, thermal efficiency of this electric apparatus is the ratio of the heat utilized for heating the water to the total heat produced.

Hence, the relation between heat produced electrically and heat absorbed usefully becomes

$$\frac{V I t}{J} \times \eta = m s (\theta_2 - \theta_1)$$

Example(1) :

The heater element of an electric kettle has a constant resistance of 100Ω and the applied voltage is 250 V . Calculate the time taken to raise the temperature of one liter of water from 15°C to 90°C assuming that 85% of the power input to the kettle is usefully employed. If the water equivalent of the kettle is 100 g , find how long will it take to raise a second liter of water through the same temperature range immediately after the first.

Sol:

Mass of water = $1000 \text{ g} = 1 \text{ kg}$ ($\because 1 \text{ cm}^3$ weight 1 gram)

Heat taken by water = $1 \times (90 - 15) = 75 \text{ kcal}$

Heat taken by the kettle = $0.1 \times (90 - 15) = 7.5 \text{ kcal}$

Total heat taken = $75 + 7.5 = 82.5 \text{ kcal}$

Heat produced electrically $H = I^2 R t / J \text{ kcal}$

Now, $I = 250/100 = 2.5 \text{ A}$, $J = 4,200 \text{ J/kcal}$; $H = 2.5^2 \times 100 \times t / 4200 \text{ kcal}$

Heat actually utilized for heating one litre of water and kettle
= $0.85 \times 2.5^2 \times 100 \times t / 4,200 \text{ kcal}$

$\therefore \frac{0.85 \times 6.25 \times 100 \times t}{4,200} = 82.5 \quad \therefore t = 10 \text{ min } 52 \text{ second}$

In the second case, heat would be required only for heating the water because kettle would be already hot.

$\therefore 75 = \frac{0.85 \times 6.25 \times 100 \times t}{4,200} \quad \therefore t = 9 \text{ min } 53 \text{ second}$

Example(2).

Two heater A and B are in parallel across supply voltage V . Heater A produces 500 kcal in 20 min. and B produces 1000 kcal in 10 min. The resistance of A is 10 ohm . What is the resistance of B ? If the same heaters are connected in series across the voltage V , how much heat will be produced in kcal in $5 \text{ min} ?$

Sol:

Heat produced = $\frac{V^2 t}{JR} \text{ kcal}$

For heater A, $500 = \frac{V^2 \times (20 \times 60)}{10 \times J} \quad \dots(i)$

For heater B, $1000 = \frac{V^2 \times (10 \times 60)}{R \times J} \quad \dots(ii)$

From Eq. (i) and (ii), we get, $R = 2.5 \Omega$

When the two heaters are connected in series, let H be the amount of heat produced in kcal. Since combined resistance is $(10 + 2.5) = 12.5 \Omega$ hence

$$H = \frac{V^2 \times (5 \times 60)}{12.5 \times J} \quad \dots(iii)$$

Dividing Eq. (iii) by Eq. (i), we have $H = 100 \text{ kcal}$.

Review the S.I. Units in your reference.

Calculation of Kilo-watt Power of a Hydroelectric Station

Let Q = water discharge rate in cubic meters/second (m^3/s), H = net water head in meter (m). $g = 9.81$, η ; overall efficiency of the hydroelectric station.

Since 1 m^3 of water weighs 1000 kg ., discharge rate is $1000 Q \text{ kg/s}$.

When this amount of water falls through a height of H meter, then energy or work available per second or available power is

$$= 1000 QgH \text{ J/s or W} = QgH \text{ kW}$$

Since the overall station efficiency is η , power actually available is $= 9.81 \eta QH \text{ kW}$.

Example(3).

A de-icing equipment fitted to a radio aerial consists of a length of a resistance wire so arranged that when a current is passed through it, parts of the aerial become warm. The resistance wire dissipates 1250 W when 50 V is maintained across its ends. It is connected to a d.c. supply by 100 meters of this copper wire, each conductor of which has resistance of $0.006 \Omega/\text{m}$.

Calculate

- (a) the current in the resistance wire
- (b) the power lost in the copper connecting wire
- (c) the supply voltage required to maintain 50 V across the heater itself.

Sol:

- (a) Current = wattage/voltage = $1250/50 = 25 \text{ A}$
- (b) Resistance of one copper conductor = $0.006 \times 100 = 0.6 \Omega$
Resistance of both copper conductors = $0.6 \times 2 = 1.2 \Omega$
Power loss = $I^2 R \text{ watts} = 25^2 \times 1.2 = 750 \text{ W}$
- (c) Voltage drop over connecting copper wire = $IR \text{ volt} = 25 \times 1.2 = 30 \text{ V}$
 \therefore Supply voltage required = $50 + 30 = 80 \text{ V}$